

### Parts List:

- |                     |   |
|---------------------|---|
| 1) Hitch Bar        | 10) End Cap                                     |
| 2) Side Plate       | 11) Bent Arm                                    |
| 3) Pivot Beam       | 12) Glide Bar                                   |
| 4) Black Bar        | 13) Strap                                       |
| 5) Pull Rod         | 14) Tray  |
| 6) 15 Degree Plate  | 15) Detent Pins (Not Shown)                     |
| 7) Bar Slide Button | 16) 2" Hitch Adaptor (1.25" Models) (Not Shown) |
| 8) Bar Slide        |   |
| 9) Handle Assembly  |   |

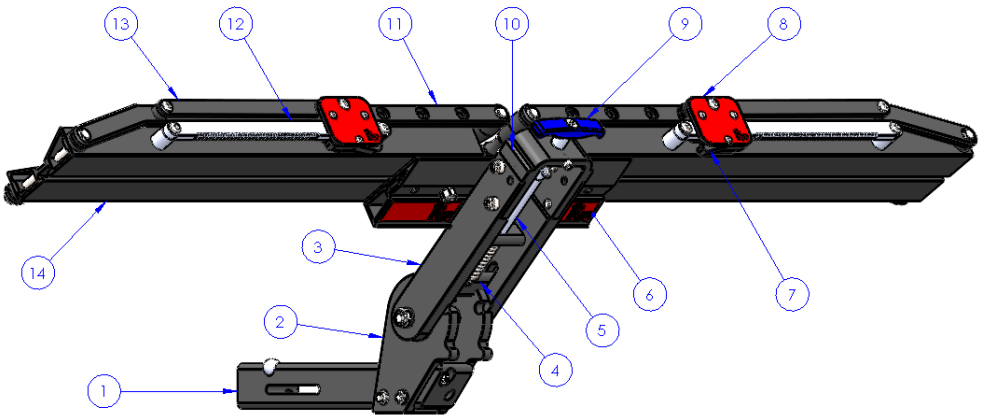

### In the Box:

- 1UP USA Equip-D Rack
- Handle Assembly with Detent Pins
- Multi Tool
- Slotted Hitch Bar Lock (2" Models)
- Rack to Receiver Security Cable and Lock (1.25" Models)
- Fat Tire Spacer Kit (Optional)
- Hardware Bag

### Product Notes:

- Fits 16"-29" wheels, up to 4.5" wide. For wider tires, use Fat Bike Spacer Kit (included).
- 50 lb weight limit on bike spots 1 and 2 (2 closest to the vehicle), 35 lb weight limit on bike spots 3 and 4 (2 furthest from vehicle).
- Equip-D Racks offered in single and double configurations.
- Two Add-Ons max for 2" models and 1 1/4" single, One Add-On max for 1 1/4" double (Add-Ons sold separately).

## **Step 1:**

- Remove Rack from box.
- Unfold Hitch parallel with the Trays.
- Remove all cardboard supports.
- Remove plastic wrap around Hitch.

**Note:** For 1.25" Equip-D Models, if receiver on vehicle is 1.25", see 2" Hitch Adapter (See page 4 for more information).

## **Step 2:**

- Position Rack with Hitch Bar facing upwards and place on a stable nonabrasive surface.
- Rotate Trays outward 90° into loading position.

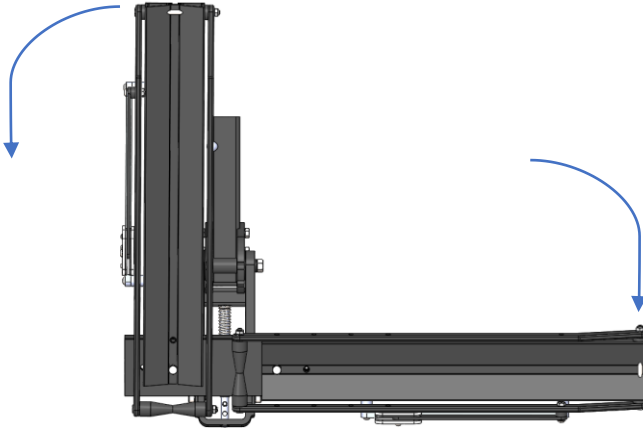

## **Step 3:**

- Insert 3/8-16 SHCS bolt into holes shown and tighten firmly with Multi Tool.

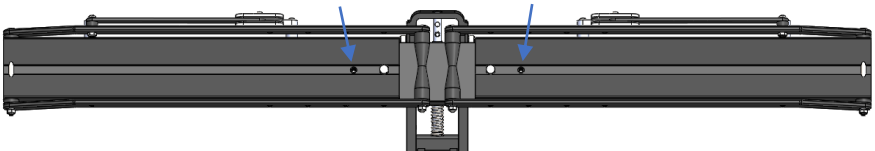

## **Step 4:**

- Install Handle Assembly through End Cap.
- Slide Detent Pins through Handle Assembly and Pull Rod.

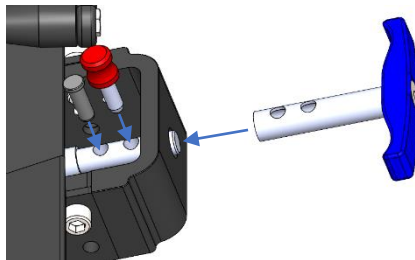

**Note:** See Rack Positions on page 4 for more information.

## **Step 5:**

- Insert Rack to desired depth in receiver. Ball must be inserted a minimum of 2".
- **Silver ball should not stick out front of receiver.**

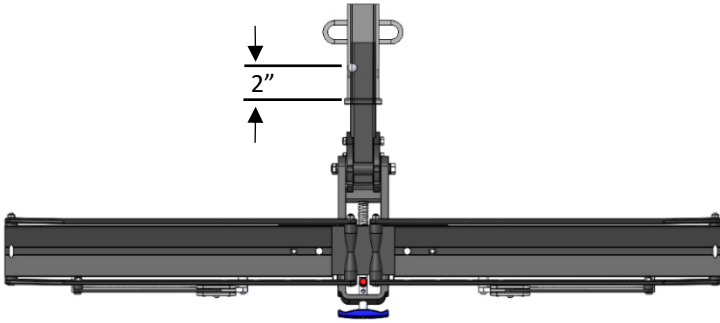

## **Step 6:**

- Pivot Rack into storage position by removing red knob Detent Pin and pulling blue Handle Assembly outward while lifting upward on End Cap.

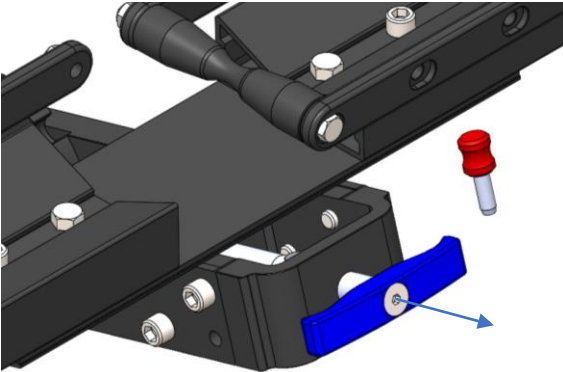

**Note:** See Rack Positions on page 4 for more information.

## **Step 7:**

- Tighten Hitch Bolt firmly with Multi Tool provided.

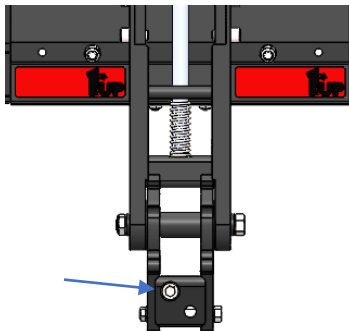

**Note:** Do not tighten Hitch Bolt if Hitch Bar is not inserted into a receiver.

## Pivoting the Rack

- Remove red knob Detent Pin and pull Handle out away from Hitch while lifting on End Cap.
- Pivot Rack toward desired position and release Handle. **Ensure Black Bar fully engages in slots.**
- **Once Black Bar is engaged, reinstall red knob Detent Pin.**

**Warning: Failure to follow above instructions may cause severe damage to bikes and/or bike rack.**

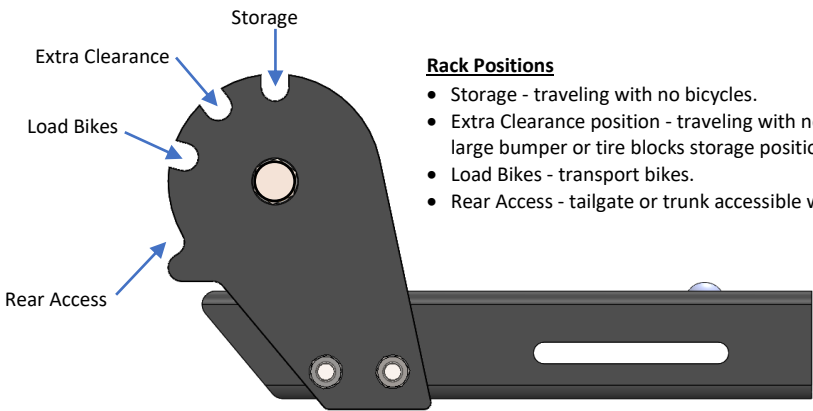
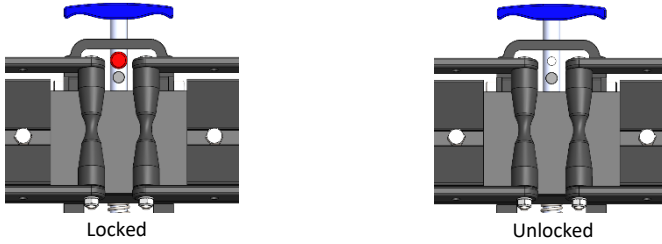

### Rack Positions

- Storage - traveling with no bicycles.
- Extra Clearance position - traveling with no bicycles, but a large bumper or tire blocks storage position.
- Load Bikes - transport bikes.
- Rear Access - tailgate or trunk accessible with bikes on.

**Note: In rear access position, Black Bar will not lock into place. Not for transporting.**

## 2" Hitch Adapter

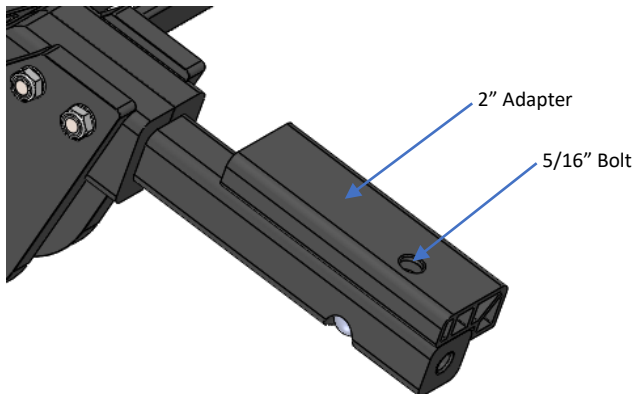

- If receiver on vehicle is 1.25", remove installed 2" Hitch Adapter with supplied Multi Tool.

## Rack to Receiver Cable and Lock (1.25" Models)

- Thread Cable Assembly through receiver chain loop (shown below).
- Slide Locking Pin through Hitch Bar lock hole.
- Once Hitch Pin Lock is through Rack, place Cable Assembly Eyelet on Pin followed by Lock Head.
- To install lock, insert key into lock head, actuate key 1/4 turn.

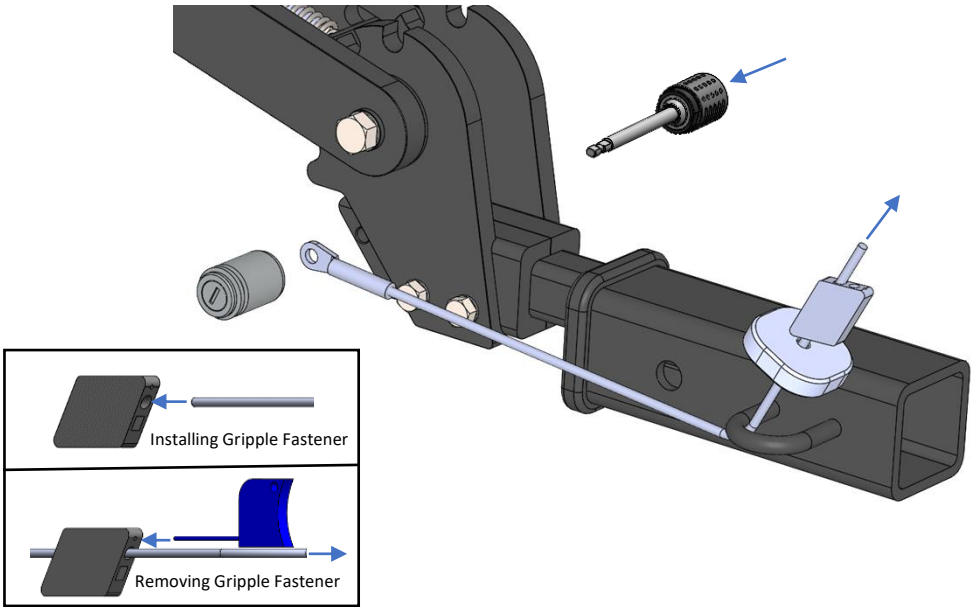

- Take slack out of Cable Assembly by pulling cable through Gripple Fastener

## Through Hitch Lock (2" Models)

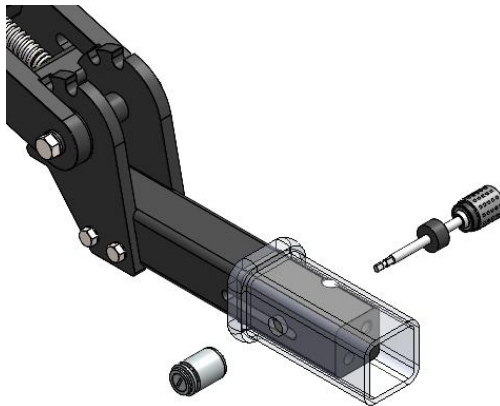

- Slide Hitch Pin through receiver pin hole and Slotted Hitch Bar.
- Install Lock Head onto end of Locking Pin.
- To install lock, insert key into lock head, actuate key 1/4 turn.

## Loading Bikes

- Repeat loading process on both driver and passenger side.
- Depress Bar Slide Button while pulling up on Bent Arm.

**Note: Do not move Bent Arms up without depressing Bar Slide Button.**

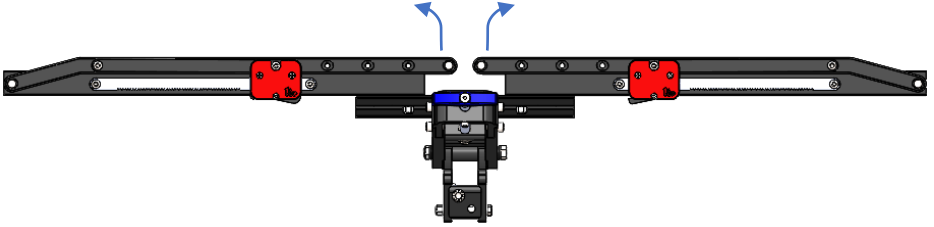

- Set bike on Trays in desired position.
- Pivot Bent Arms down to tires firmly.

**Note:**

- **When loading multiple bikes, stagger them to avoid seat and handlebar interference.**
- **Check for interference between Strap nut and tire. If interference occurs reverse button head and nut orientation (button head to inside of Bent Arms and nut on outside of Strap).**



## Unloading Bikes

- Repeat unloading process on both driver and passenger side.
- Compress Bent Arm/Spool into tire slightly while depressing Bar Slide Button. This relieves pressure and allows Bar Slide to easily unlock.
- Pivot Bent Arm from bike to unload.

## Wheel Settings

- The Rack is set to hold 26", 27.5", 29", or 700-C wheels. If bike tires are smaller, see instructions below to adjust spools accordingly.

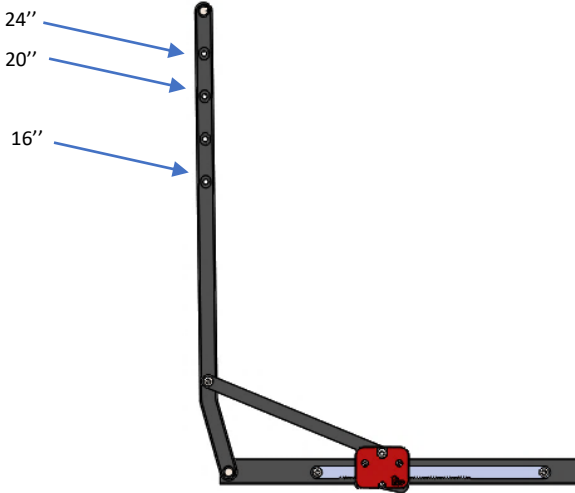

- With a ½" wrench, remove hex nut and washer.
- Slide bolt out of spools and re-assemble spools in desired wheel position, firmly tightening hex nut.

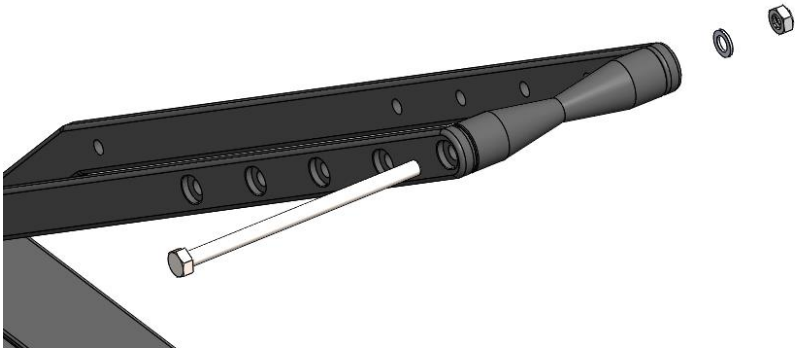

## Additional Instructions

- Tighten Hitch Bolt periodically.
- Remove Rack from receiver at least every two weeks and clean receiver so Rack does not seize in receiver.
- Remove road debris off nuts and bolts to prevent corrosion.
- Inspect hardware on Rack periodically to ensure proper working conditions.
- Certain car wash chemicals may damage Rack finish. Please use caution when cleaning vehicle and/ or Rack.
- Failure to follow above instructions, or misuse of bike rack, may void warranty.

Questions or comments? Contact our support team via email at [email@1up-usa.com](mailto:email@1up-usa.com)