

Parts List:

- | | |
|------------------------|-------------------------|
| 1) 2" Hitch | 11) Passenger Side Tray |
| 2) Left 2" Side Plate | 12) Bent Arm |
| 3) Left Pivot Beam | 13) 19" Strap |
| 4) Cross Bar | 14) Glide Bar |
| 5) Black Bar | 15) Red Lever |
| 6) Right 2" Side Plate | 16) 15° Plate |
| 7) Gold Bar Knob | 17) Super Duty Bar |
| 8) Gold Bar | 18) Blue Lever |
| 9) Right Pivot Beam | 19) Driver Side Tray |
| 10) Tap Plate | |

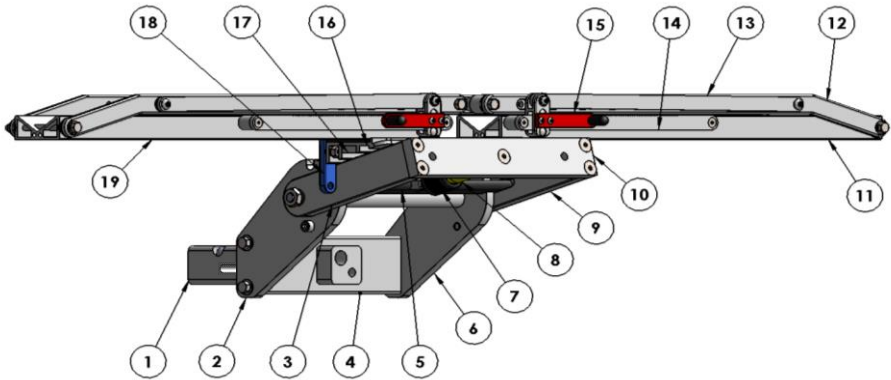

In the Box:

- 1UP USA 2" Heavy or Super Duty Rack
- (2) Security Wrench
- Slotted Hitch Bar Lock

Product Notes:

- Fits 16"-29" wheels, up to 3.1" wide. For wider tires, use a Fat Bike Spacer Kit (sold separately).
- Heavy Duty rated to hold up to 50 lb/bike spot. Super Duty rated to hold up to 75 lb/bike spot.
- 2" Heavy Duty Rack offered in double configuration only.
- 2" Super Duty Rack offered in single and double configurations.
- With addition of two Add-Ons (sold separately), this rack can hold a maximum of three bikes.

Note: For 2" Super Duty Double, with addition of two Add-Ons (sold separately), this rack can hold a maximum of four bikes when all bikes are 50 lb or less. If any bike weighs 51 lb – 75 lb, only one Add-On may be used. 2" Super Duty Double Rack is rated to hold up to 75 lb per bike spot.

Step 1:

- Remove Rack from box.
- Unfold Hitch parallel with Trays.
- Remove all cardboard supports.
- Remove plastic wrap around Hitch.

Step 2:

- Position Rack with Hitch Bar facing upwards and place on a stable nonabrasive surface.
- Rotate Blue Levers outward 90°.

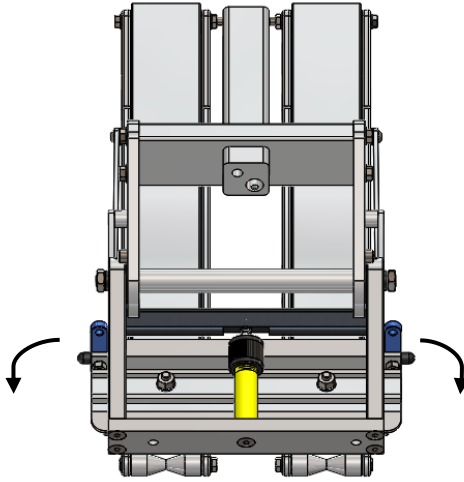

Step 3:

- Rotate Trays outward 90° into loading position.

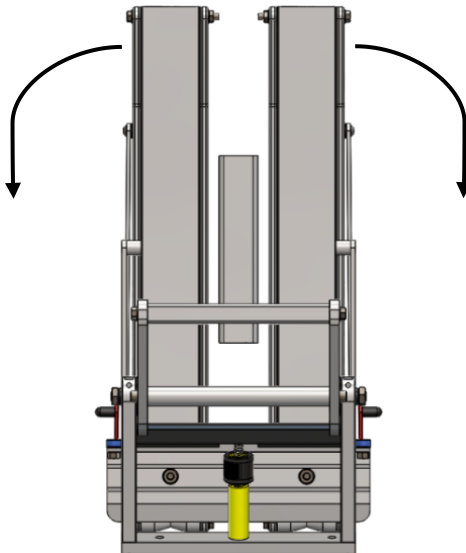

Step 3 Cont'd:

- Rotate Blue Levers back into original locking position.
- Ensure Blue Levers are always in locked position when using Rack.

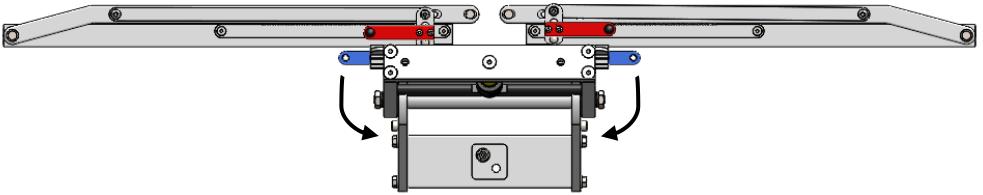

Step 4:

- Insert Rack to desired depth in receiver. Ball must be inserted a minimum of 2".
- Silver ball should not stick out front of receiver.

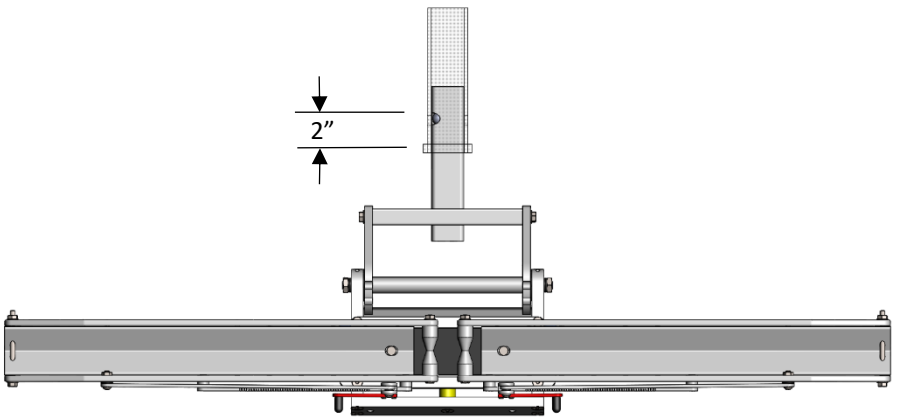

Step 5:

- Pivot Rack into storage position by pulling Black Bar back and lifting upward on Tap Plate.

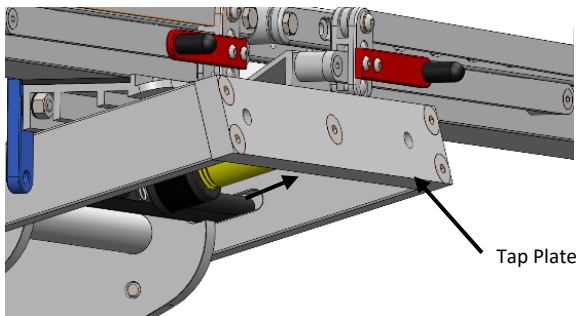

Note: See Rack Positions on page 4 for more information.

Step 6:

- Tighten Security Hitch Bolt firmly with gold Security Wrench provided.

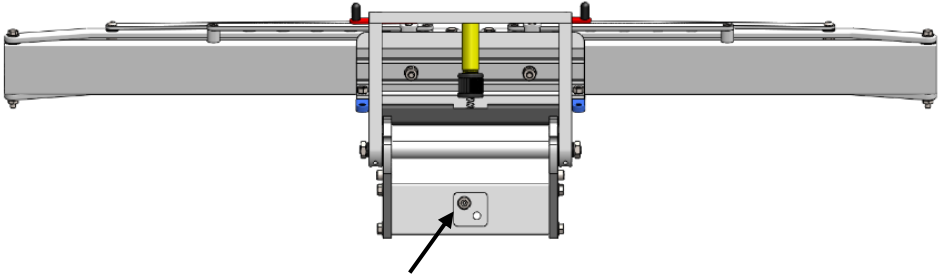

Note: Do not tighten Security Hitch Bolt if Hitch Bar is not inserted into a receiver.

Pivoting the Rack

- Pull Black Bar out away from Hitch while lifting on Tap Plate.
- Pivot Rack towards desired position and release Black Bar. Ensure it is fully engaged in slots.
- Once positioned, tighten Gold Bar Knob to lock Black Bar in position.

Rack Positions

- Storage - traveling with no bicycles.
- Extra Clearance position - traveling with no bicycles, but a large bumper or tire blocks storage position.
- Load Bikes - transport bikes.
- Rear Access - tailgate or trunk accessible with bikes on.

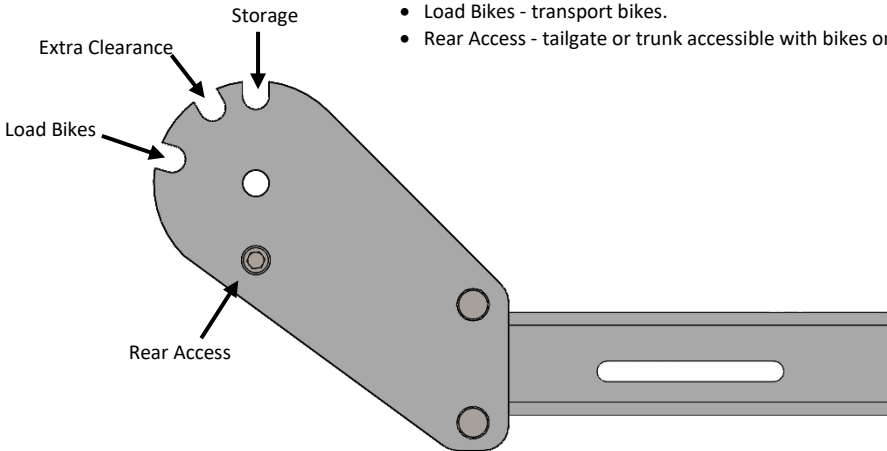

Note: In rear access position, Black Bar will not lock into place. Not for transporting.

Loading Bikes

- Repeat loading process on both driver and passenger side.
- Lift Red Lever up parallel with Glide Bar while pulling up on Bent Arm.

Note: Do not move Bent Arms up without lifting the Red Lever.

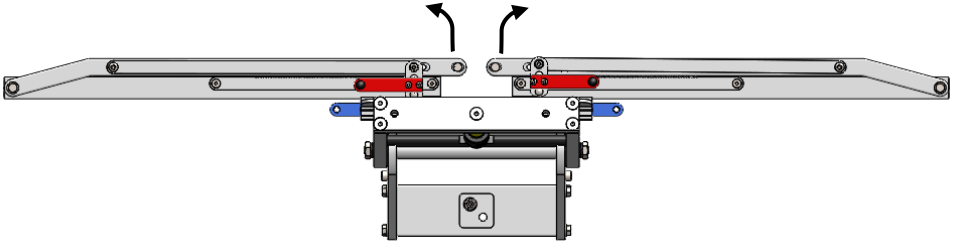

- Set bike on Trays in desired position.
- Pivot Bent Arms down to tires firmly.

Note: When loading multiple bikes, stagger them to avoid seat and handlebar interference.



Unloading Bikes

- Repeat unloading process on both driver and passenger side.
- Compress Bent Arm/Spool into tire slightly while lifting on Red Lever. This relieves pressure and allows the Red Lever to easily unlock.
- Pivot Bent Arm from bike to unload.

Wheel Settings

- The Rack is set to hold 26", 27.5", 29", or 700-C wheels. If bike tires are smaller, see instructions below to adjust Spools accordingly.

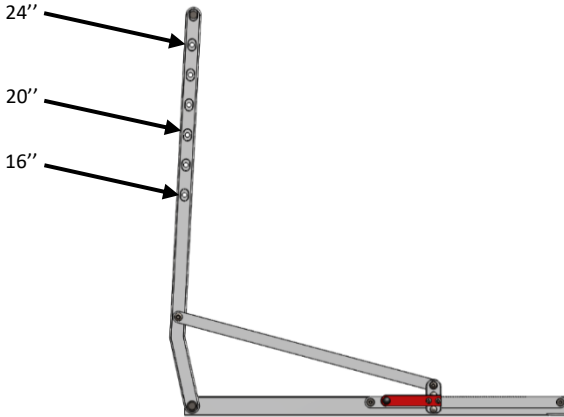

- With a ½" wrench, remove hex nut and washer.
- Slide bolt out of Spools and re-assemble Spools in desired wheel position, firmly tightening hex nut.

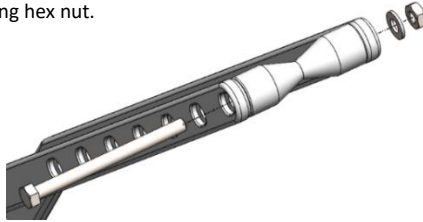

Locking Rack to Vehicle

- Slide Hitch Pin through receiver pin hole and Slotted Hitch Bar.
- Install Lock Head to end of Locking Pin.

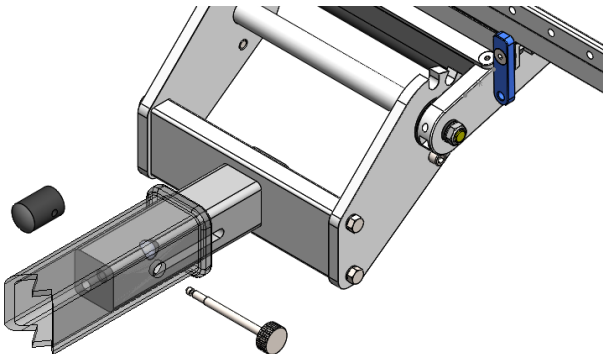

Additional Instructions

- Tighten Security Hitch Bolt periodically.
- Remove Rack from receiver at least every two weeks and clean receiver so Rack does not seize in receiver.
- Remove road debris off nuts and bolts to prevent corrosion.
- Inspect hardware on Rack periodically to ensure proper working conditions.
- Certain car wash chemicals may damage Rack finish. Please use caution when cleaning vehicle and/ or Rack.

Questions or comments? Contact our support team via email at email@1up-usa.com