

Parts List:

- 1) (1) - Handle
- 2) (2) - 3/8-16 x .875" Set Screw
- 3) (2) - Security Bolt
- 4) (1) - Keyhole Plate
- 5) (1) - Top Bracket
- 6) (1) - Bottom Bracket
- 7) (2) - 1/2-13 x 1.75" Cap Screw
- 8) (1) - 3/16" Allen Wrench (not shown)

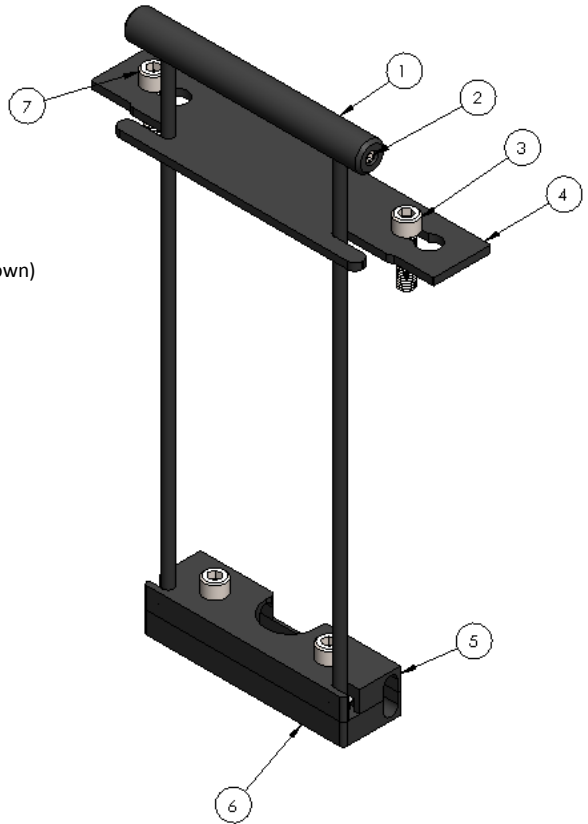

Product Notes:

- Available in two, three and four bike configurations
- Compatible with existing racks
- Base Rack Security Wrench required for assembly

Step 1

Assemble Handle unit by inserting 3/8" diameter rods into handle. **Verify the rods are fully inserted.** Install 3/8-18 set screws and tighten until snug with supplied Allen wrench.

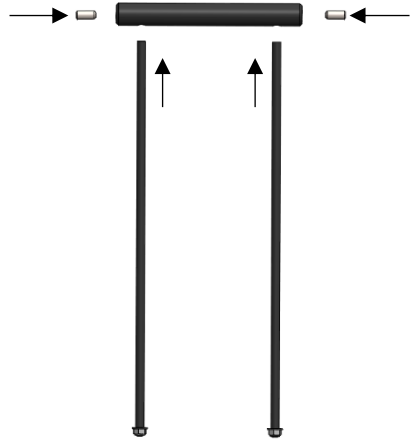

Step 2

Install Keyhole Plate to base rack Tap Plate using (1) 1/2-13 Cap Screw and (1) Security Bolt. Use rack Security Wrench to tighten (not supplied).

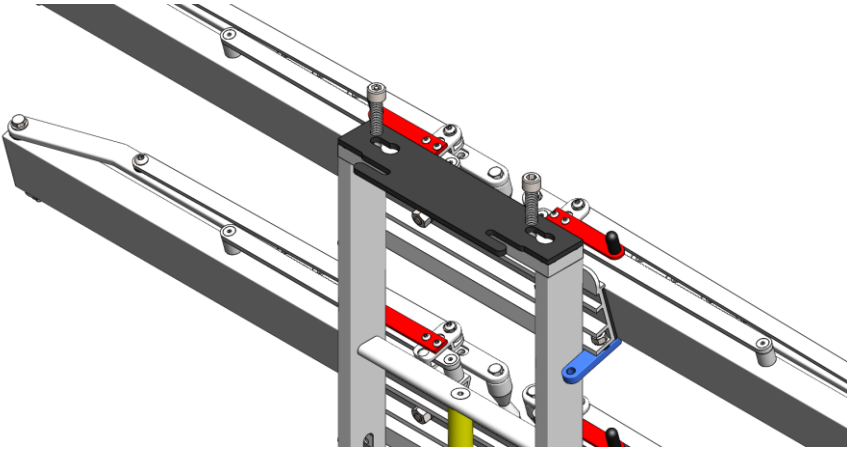

Step 3

Assemble Top and Bottom Bracket to existing rack Black Bar. Do not fully tighten 1/2-13 Cap Screw or Security Bolt.

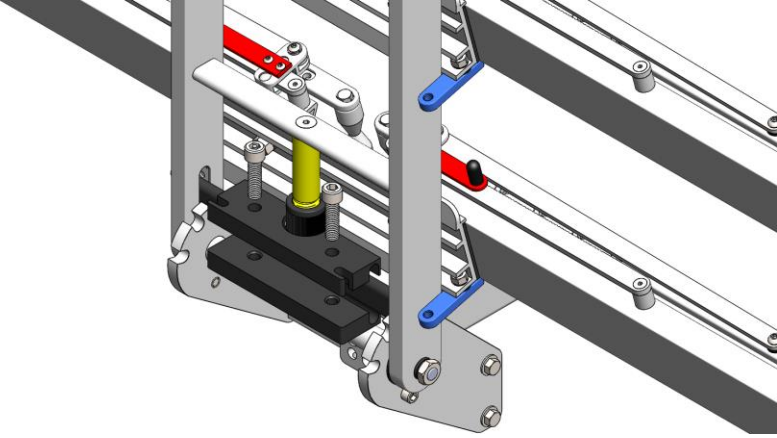

Step 4

Position Handle unit around Keyhole Plate so that 3/8" diameter rods rest in the Keyhole Plate slots. Guide the bottom end of rods into slot of Top Bracket so flange nuts fall into machined hole.

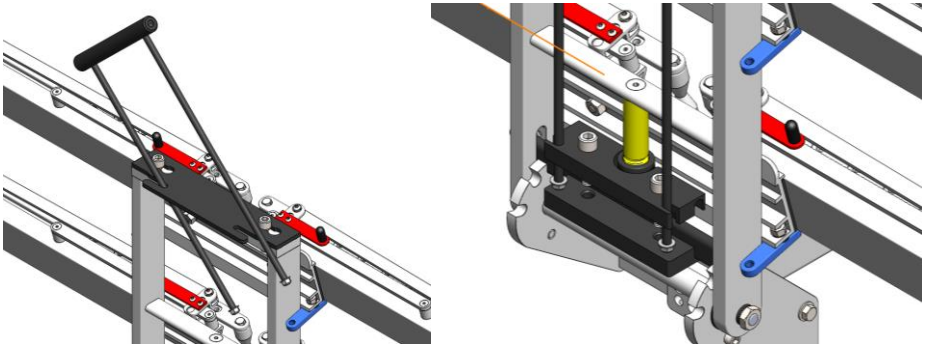

Step 5

Using rack Security Wrench, tighten already installed 1/2-13 Cap Screw and Security bolt. Verify both are firmly tightened.

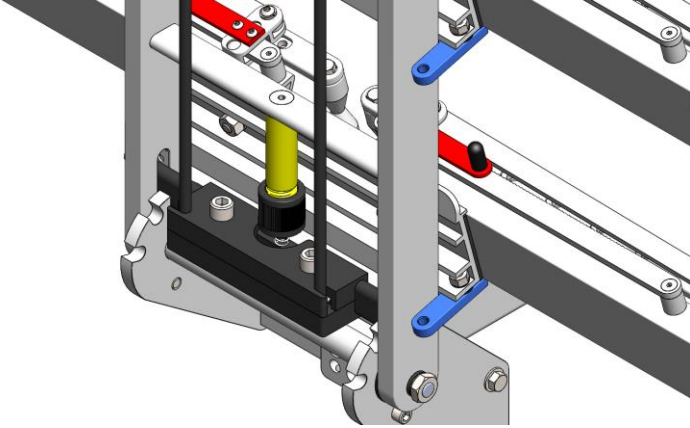

Step 6

Pull Handle to insure all moves freely and rack can be adjusted.

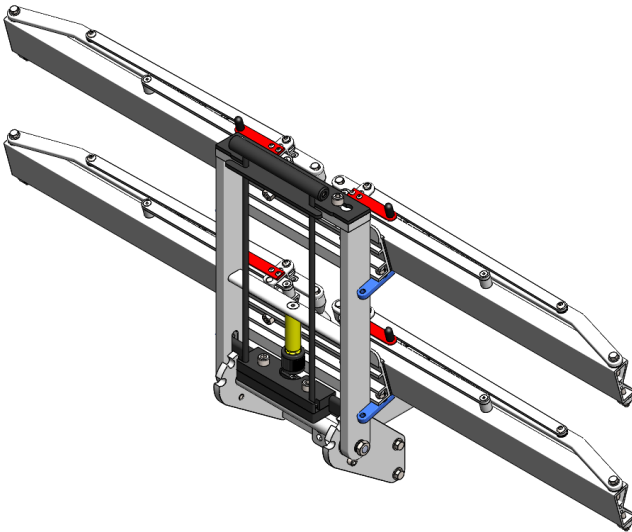

Additional Instructions

- Wipe salt off of the nuts and bolts with a damp cloth to prevent corrosion.
- Check and retighten any hardware on the rack periodically to ensure proper working conditions.

Questions or comments? Contact our support team via email at email@1up-usa.com